

BLOCK02

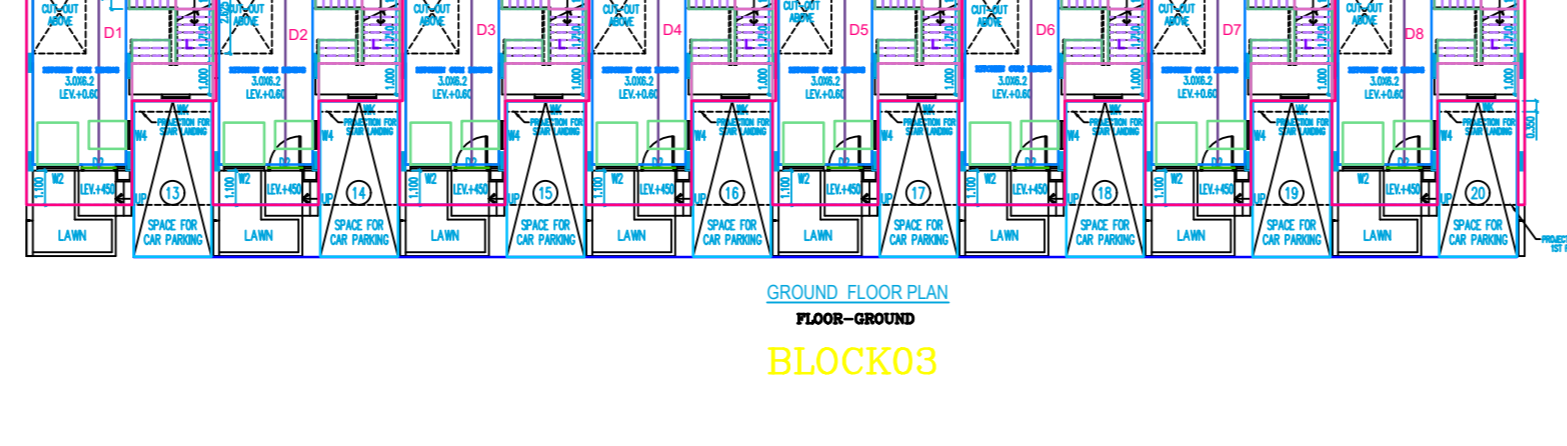

BLOCK03

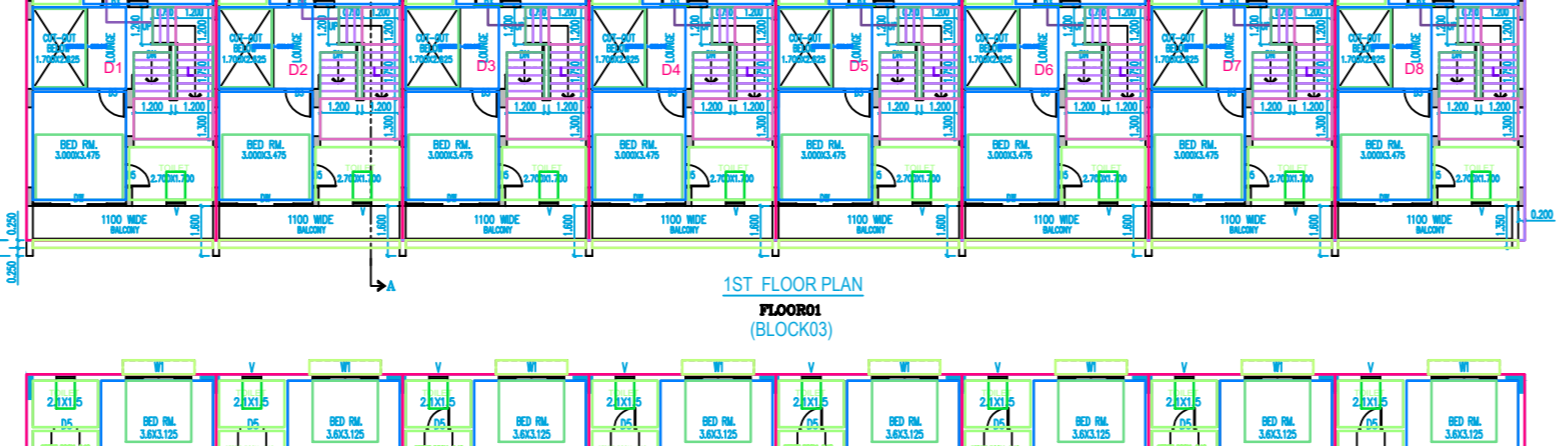
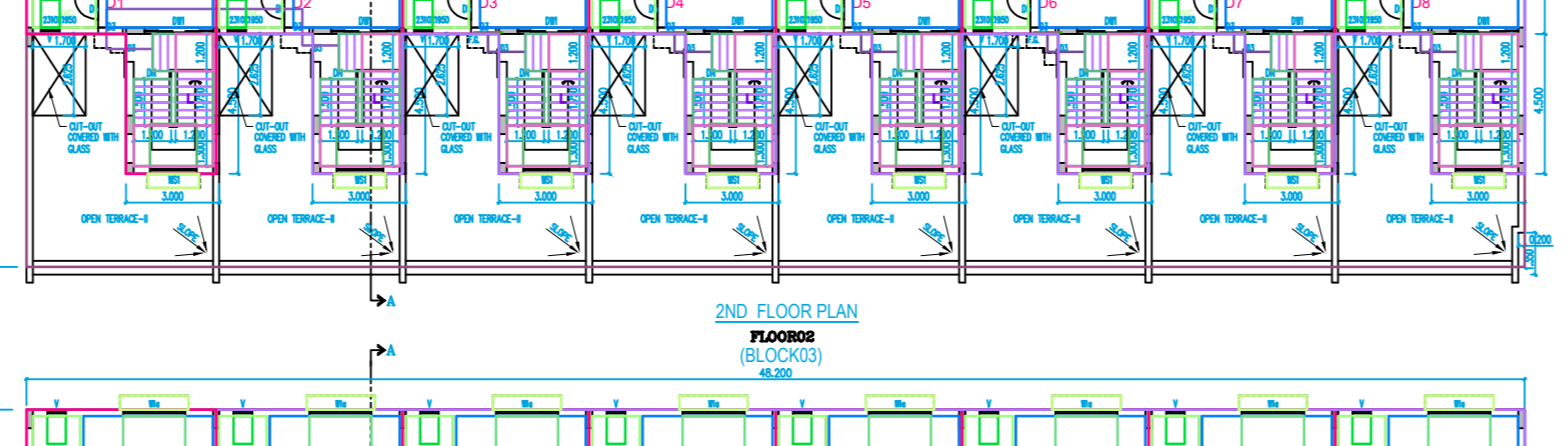
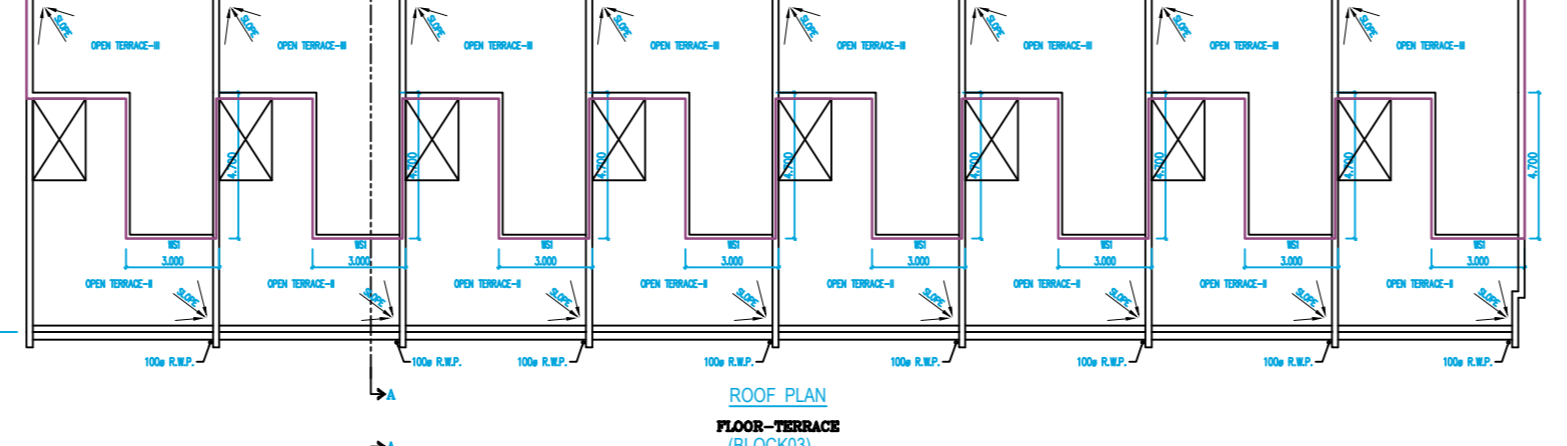
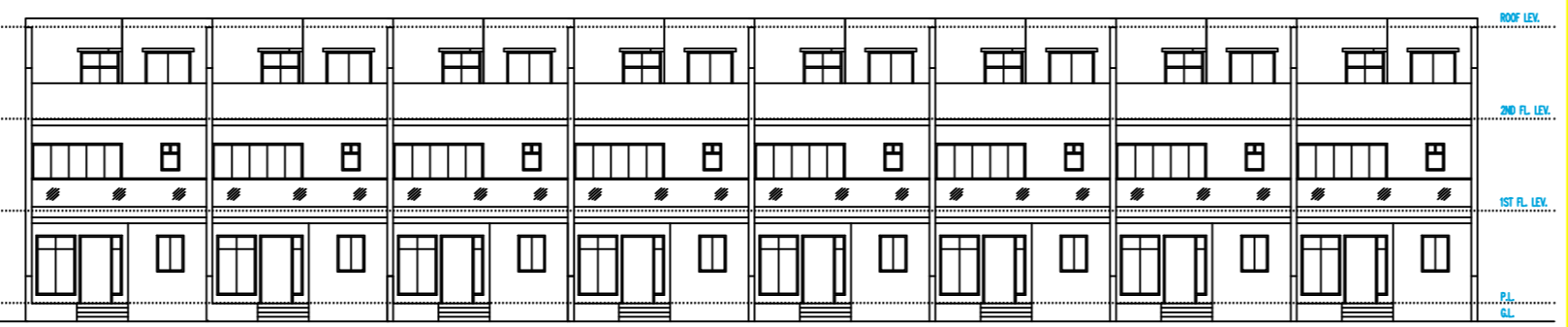
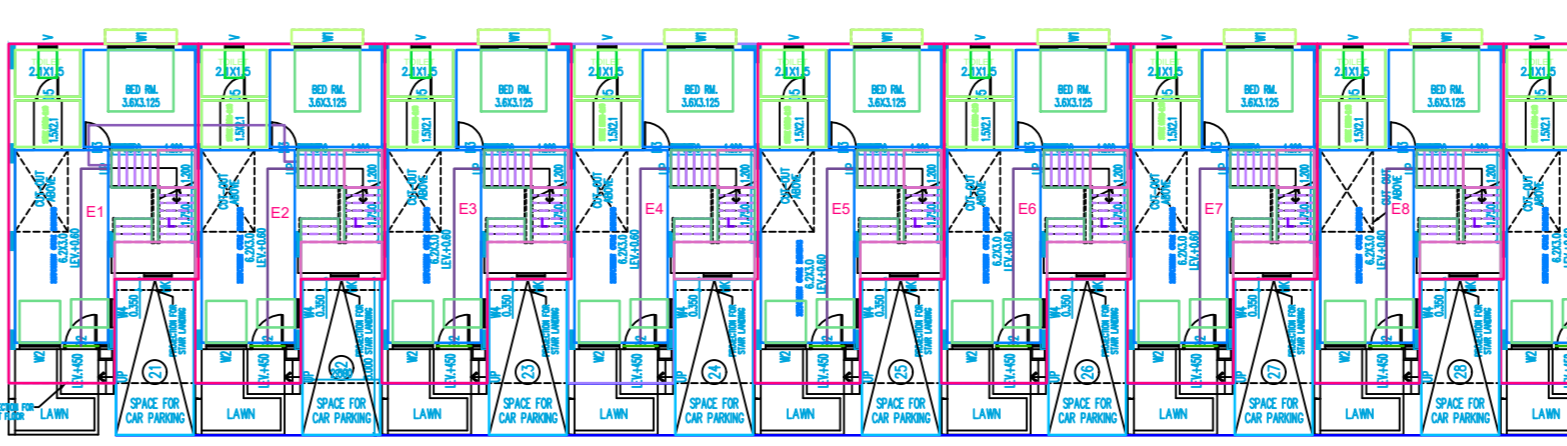
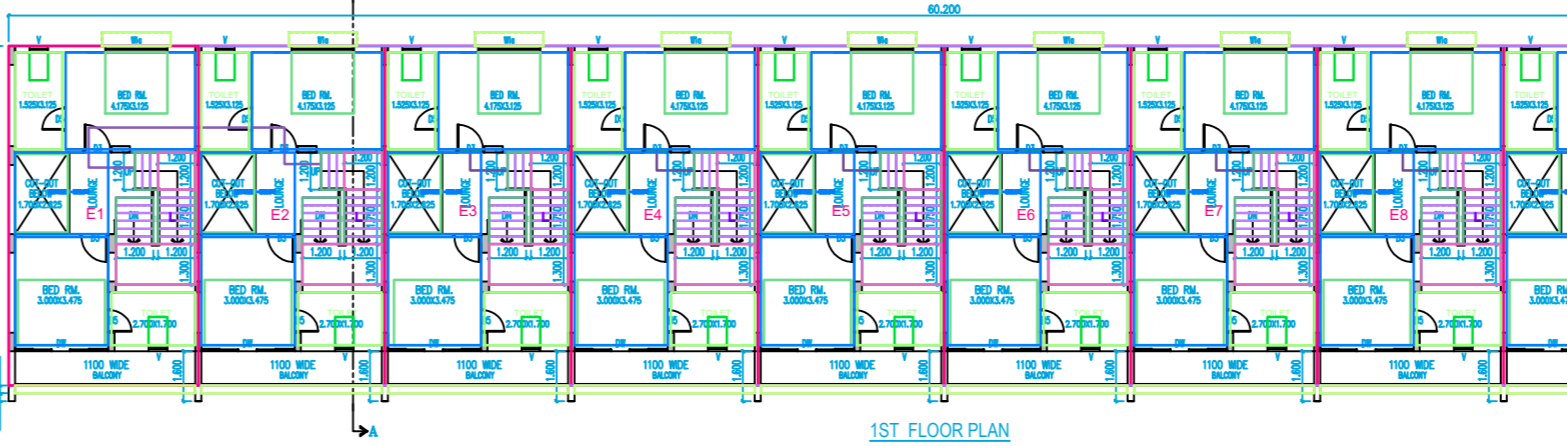
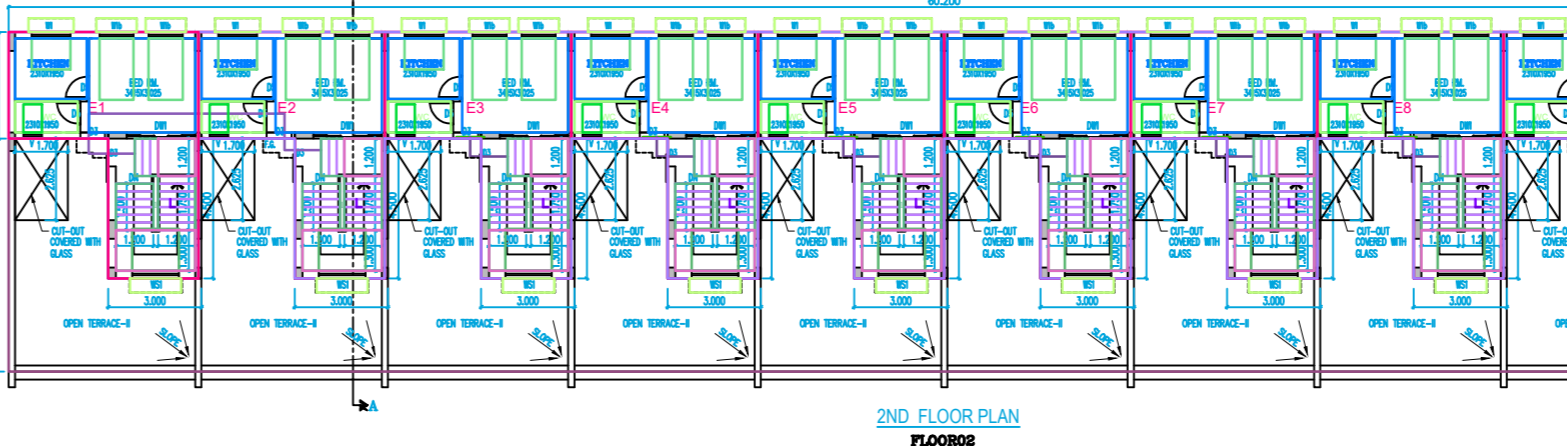
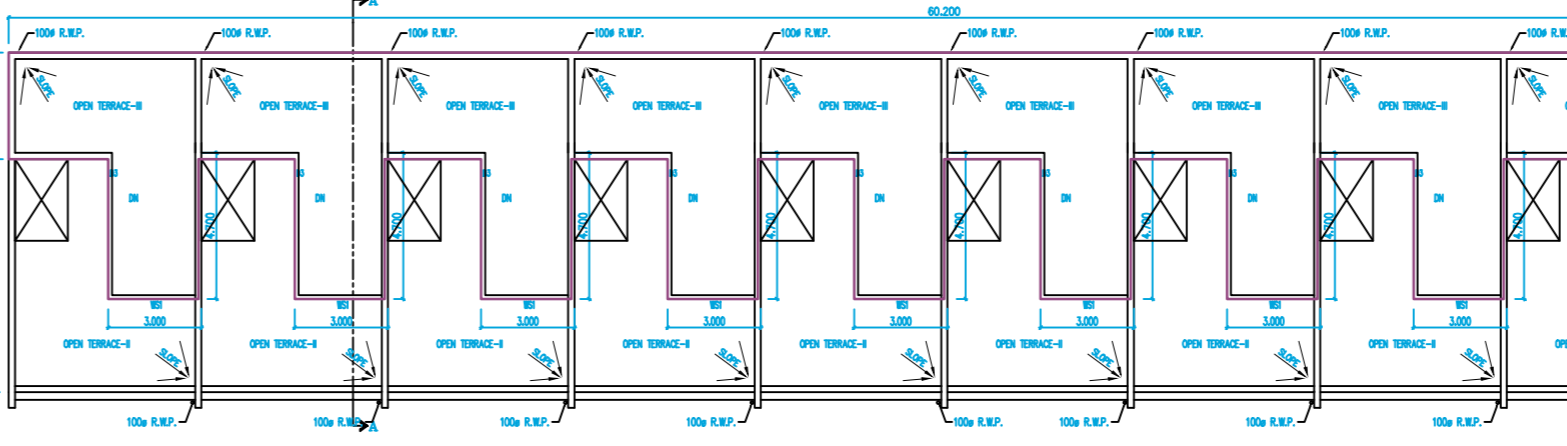

BLOCK04

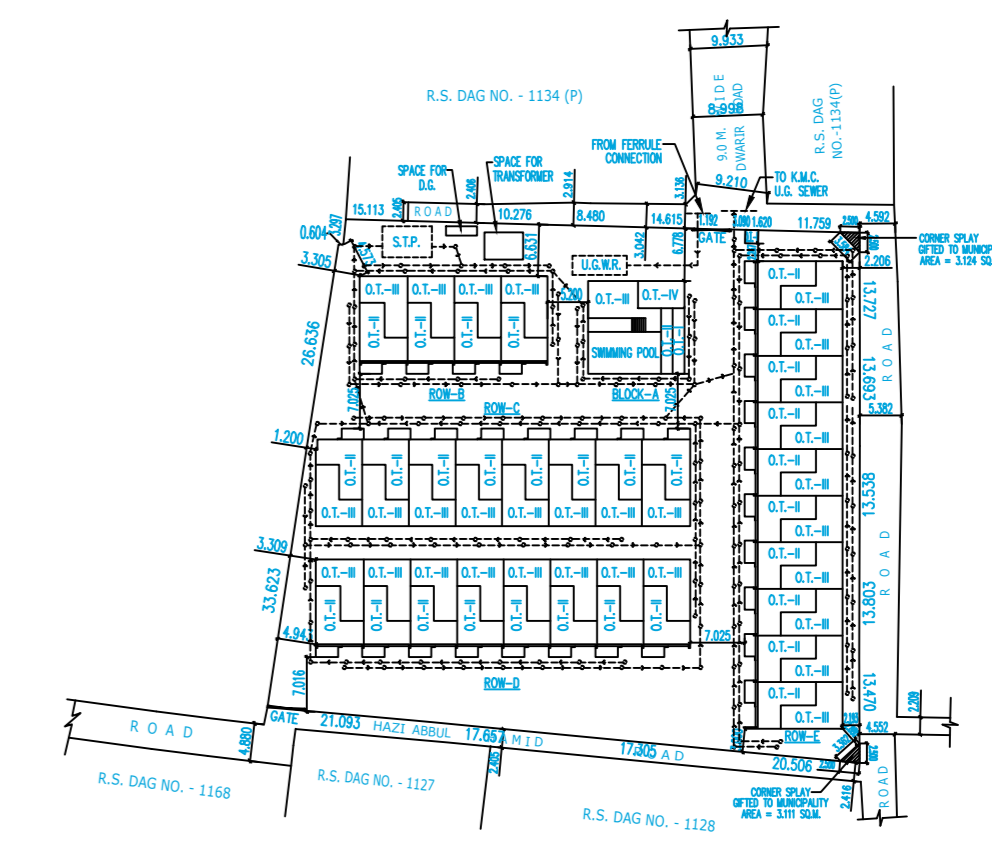

SITE PLAN SCALE - 1:800

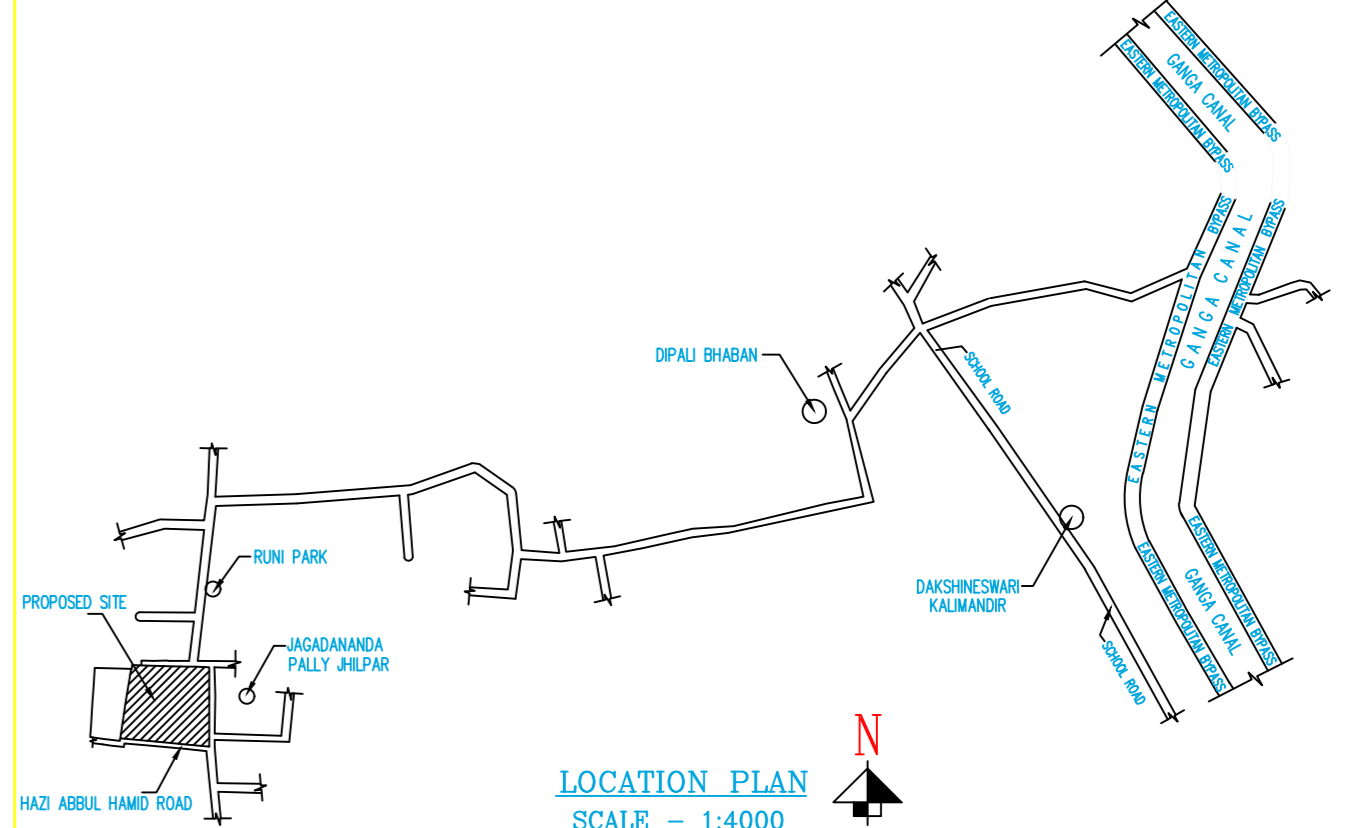

LOCATION PLAN SCALE - 1:4000

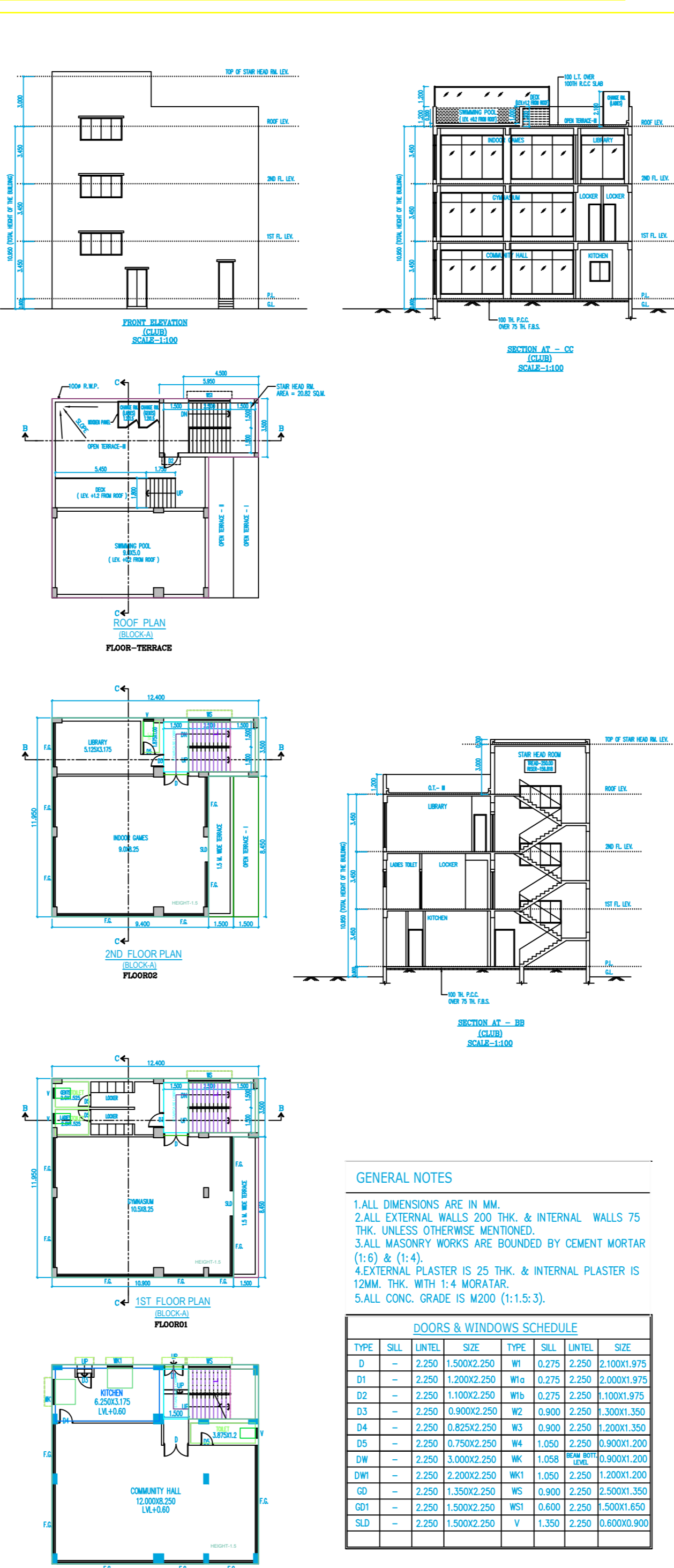

BLOCK01

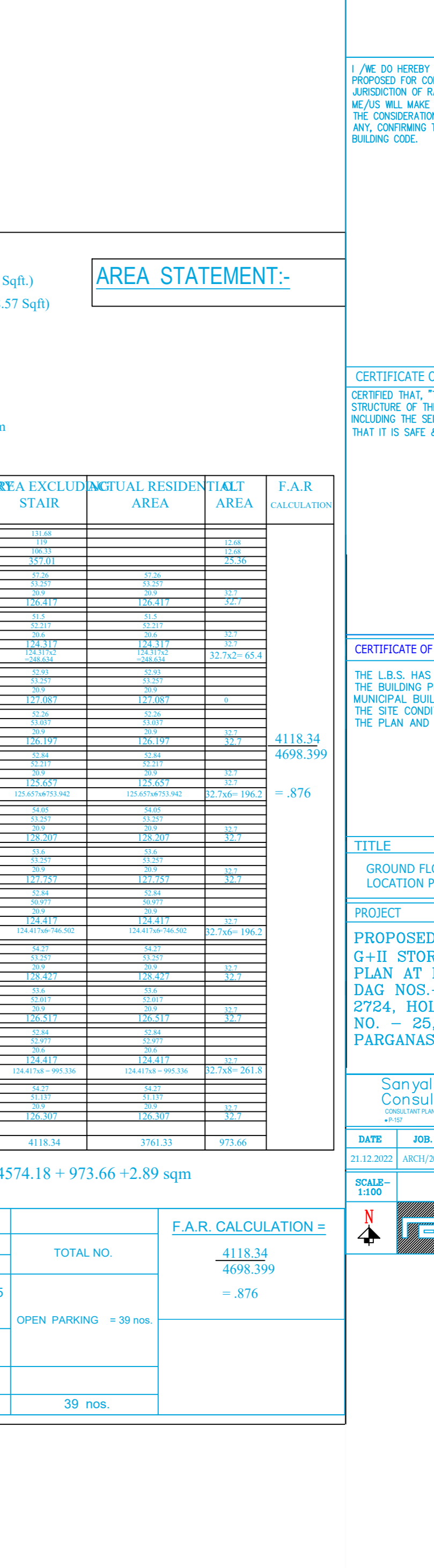
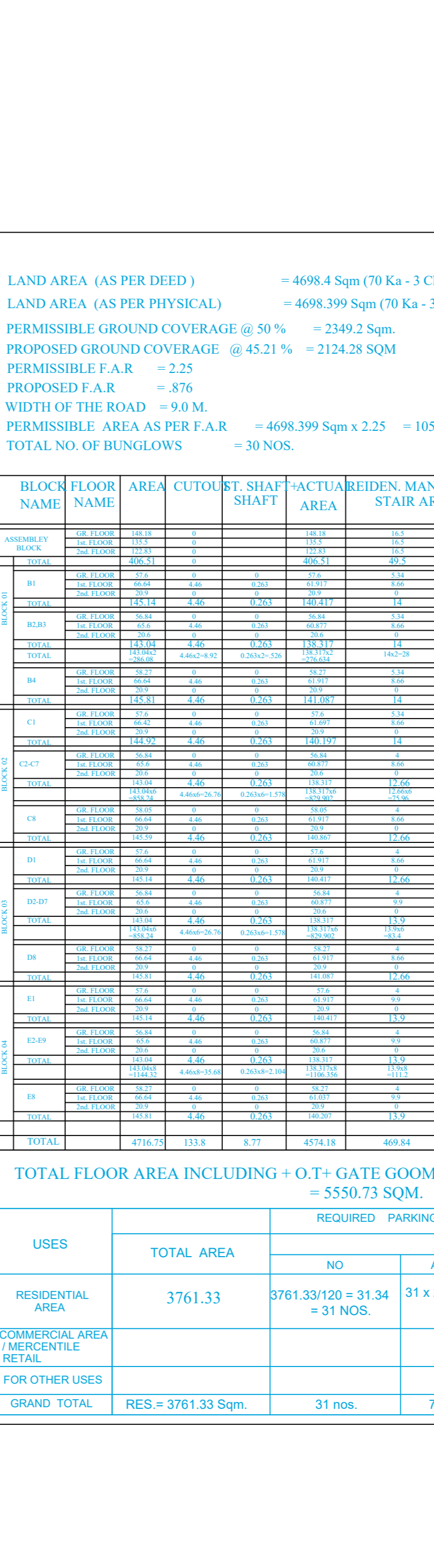
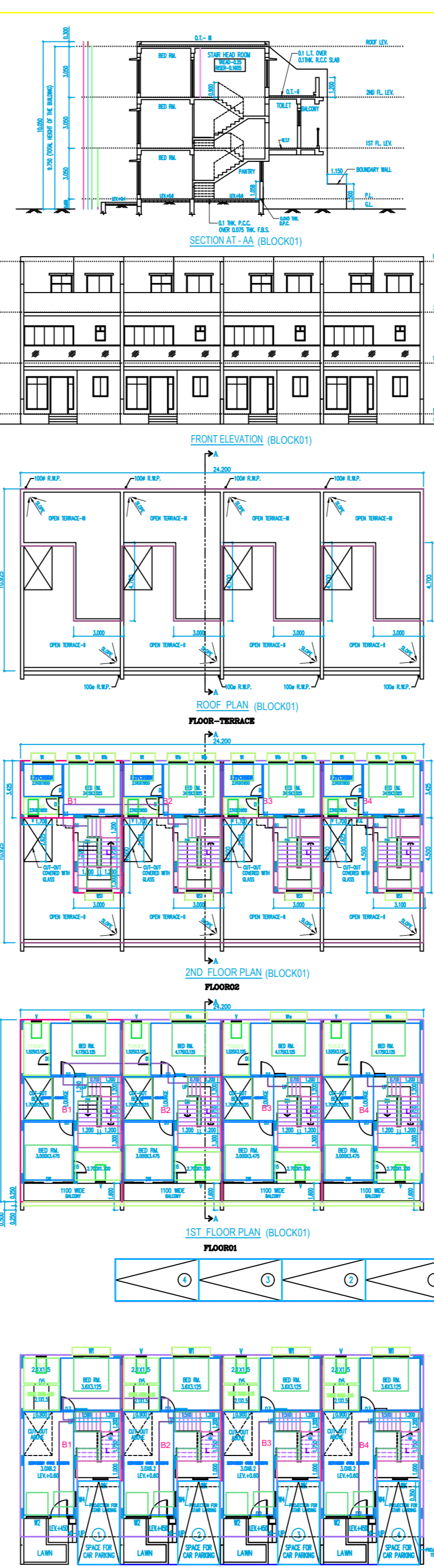

LAND AREA (AS PER DEED) = 4698.4 Sqm (70 Ka - 3 Ch - 38.58 Sqft.)
 LAND AREA (AS PER PHYSICAL) = 4698.399 Sqm (70 Ka - 3 Ch - 38.57 Sqft.)
 PERMISSIBLE GROUND COVERAGE @ 50% = 2349.2 Sqm
 PROPOSED GROUND COVERAGE @ 45.21% = 2124.28 SQM
 PERMISSIBLE F.A.R. = 2.25
 WIDTH OF THE ROAD = 9.0 M
 PROPOSED F.A.R. = 876
 PERMISSIBLE AREA AS PER F.A.R. = 4098.399 Sqm x 2.25 = 10571.4 sqm
 TOTAL NO. OF BUNGLOWS = 30 NOS.

AREA STATEMENT:-

BLOCK NAME	FLOOR NAME	AREA	CUTOFF	SHAFT	ACTUAL AREA	REDDEN STAIR AREA	MANDATA STAIR AREA	EXCLD STAIR AREA	ACTUAL RESIDENTIAL AREA	TOTAL AREA	F.A.R. CALCULATION
BLOCK 02	GROUND FLOOR	2124.28	0.00	0.00	2124.28	0.00	0.00	0.00	2124.28	2124.28	4118.34 4698.399 = 876
	1ST FLOOR	2124.28	0.00	0.00	2124.28	0.00	0.00	0.00	2124.28	2124.28	
	2ND FLOOR	2124.28	0.00	0.00	2124.28	0.00	0.00	0.00	2124.28	2124.28	
	ROOF	0.00	0.00	0.00	0.00	0.00	0.00	0.00	0.00	0.00	
BLOCK 03	GROUND FLOOR	2124.28	0.00	0.00	2124.28	0.00	0.00	0.00	2124.28	2124.28	4118.34 4698.399 = 876
	1ST FLOOR	2124.28	0.00	0.00	2124.28	0.00	0.00	0.00	2124.28	2124.28	
	2ND FLOOR	2124.28	0.00	0.00	2124.28	0.00	0.00	0.00	2124.28	2124.28	
	ROOF	0.00	0.00	0.00	0.00	0.00	0.00	0.00	0.00	0.00	
BLOCK 04	GROUND FLOOR	2124.28	0.00	0.00	2124.28	0.00	0.00	0.00	2124.28	2124.28	4118.34 4698.399 = 876
	1ST FLOOR	2124.28	0.00	0.00	2124.28	0.00	0.00	0.00	2124.28	2124.28	
	2ND FLOOR	2124.28	0.00	0.00	2124.28	0.00	0.00	0.00	2124.28	2124.28	
	ROOF	0.00	0.00	0.00	0.00	0.00	0.00	0.00	0.00	0.00	

TOTAL FLOOR AREA INCLUDING + O.T+ GATE GOOMTY = 4574.18 + 973.66 + 2.89 sqm = 5550.73 SQM.

USES	TOTAL AREA	REQUIRED PARKING		TOTAL NO.	F.A.R. CALCULATION =
		NO	AREA		
RESIDENTIAL AREA	3761.33	3761.33/120 = 31.34	31 x 25 = 775	4118.34	4698.399
COMMERCIAL AREA / MERCANTILE AREA					
FOR OTHER USES					
GRAND TOTAL	RES = 3761.33 Sqm.	31 nos.	775	39 nos.	= 876

1. I, ENGINEER ARCHITECT AND E.S.E. DURING CONSTRUCTION OF THE BUILDING, HAVE PERSONALLY SUPERVISED AND SO DESIGN BY ME AND ALL THE FOUNDATION AND SUPERSTRUCTURE SAFETY IN ALL RESPECTS. HOLDING THE CERTIFICATE OF BUILDING CODE AND SETTLEMENT OF THE SANCTION PLAN. 2. I HAVE TO BE RESPONSIBLE FOR THE STRUCTURAL STABILITY OF BUILDING AND SO DESIGN BY ME AND ALL THE FOUNDATION AND SUPERSTRUCTURE SAFETY IN ALL RESPECTS. HOLDING THE CERTIFICATE OF BUILDING CODE AND SETTLEMENT OF THE SANCTION PLAN. 3. I HAVE TO BE RESPONSIBLE FOR THE STRUCTURAL STABILITY OF BUILDING AND SO DESIGN BY ME AND ALL THE FOUNDATION AND SUPERSTRUCTURE SAFETY IN ALL RESPECTS. HOLDING THE CERTIFICATE OF BUILDING CODE AND SETTLEMENT OF THE SANCTION PLAN. 4. I HAVE TO BE RESPONSIBLE FOR THE STRUCTURAL STABILITY OF BUILDING AND SO DESIGN BY ME AND ALL THE FOUNDATION AND SUPERSTRUCTURE SAFETY IN ALL RESPECTS. HOLDING THE CERTIFICATE OF BUILDING CODE AND SETTLEMENT OF THE SANCTION PLAN. 5. I HAVE TO BE RESPONSIBLE FOR THE STRUCTURAL STABILITY OF BUILDING AND SO DESIGN BY ME AND ALL THE FOUNDATION AND SUPERSTRUCTURE SAFETY IN ALL RESPECTS. HOLDING THE CERTIFICATE OF BUILDING CODE AND SETTLEMENT OF THE SANCTION PLAN.

1. I, ENGINEER ARCHITECT AND E.S.E. DURING CONSTRUCTION OF THE BUILDING, HAVE PERSONALLY SUPERVISED AND SO DESIGN BY ME AND ALL THE FOUNDATION AND SUPERSTRUCTURE SAFETY IN ALL RESPECTS. HOLDING THE CERTIFICATE OF BUILDING CODE AND SETTLEMENT OF THE SANCTION PLAN. 2. I HAVE TO BE RESPONSIBLE FOR THE STRUCTURAL STABILITY OF BUILDING AND SO DESIGN BY ME AND ALL THE FOUNDATION AND SUPERSTRUCTURE SAFETY IN ALL RESPECTS. HOLDING THE CERTIFICATE OF BUILDING CODE AND SETTLEMENT OF THE SANCTION PLAN. 3. I HAVE TO BE RESPONSIBLE FOR THE STRUCTURAL STABILITY OF BUILDING AND SO DESIGN BY ME AND ALL THE FOUNDATION AND SUPERSTRUCTURE SAFETY IN ALL RESPECTS. HOLDING THE CERTIFICATE OF BUILDING CODE AND SETTLEMENT OF THE SANCTION PLAN. 4. I HAVE TO BE RESPONSIBLE FOR THE STRUCTURAL STABILITY OF BUILDING AND SO DESIGN BY ME AND ALL THE FOUNDATION AND SUPERSTRUCTURE SAFETY IN ALL RESPECTS. HOLDING THE CERTIFICATE OF BUILDING CODE AND SETTLEMENT OF THE SANCTION PLAN. 5. I HAVE TO BE RESPONSIBLE FOR THE STRUCTURAL STABILITY OF BUILDING AND SO DESIGN BY ME AND ALL THE FOUNDATION AND SUPERSTRUCTURE SAFETY IN ALL RESPECTS. HOLDING THE CERTIFICATE OF BUILDING CODE AND SETTLEMENT OF THE SANCTION PLAN.

CERTIFICATE OF ARCHITECT
 THE U.S.S. HAS CERTIFIED ON THE PLAN (STEP) WITH FULL RESPONSIBILITY THAT THE BUILDING PLAN HAS BEEN DRAWN UP AS PER PROVISION OF WEST BENGAL MUNICIPAL BUILDING RULES 2007, AS AMENDED FROM TIME TO TIME AND THAT THE SITE CONDITION INCLUDING THE WIDTH OF THE BUILDING ROAD CONFORM WITH THE PLAN AND IT IS A BUILDABLE SITE AND NOT A TANK OF A FILLED UP TANK.

TITLE
 GROUND FLOOR PLAN, 1st FLOOR, 2nd FLOOR, SITE PLAN, LOCATION PLAN, DETAIL OF U.G.W.R. & S.T.P.

PROJECT
 PROPOSED G+II STORED (9.75 M.) RESIDENTIAL & G+II STORED (10.95 M.) ASSEMBLY PLAN AT MOTIJA - BAGADIAL, P.I. NO.-71, L.R. DAG NOS-1320 & 1321, L.R. KHATAN NOS-2712 & 2724, HOLDING NO. - 1646, DWARIR ROAD, WARD NO. - 55, P.S. - SONAREPUR, DISTRICT - SOUTH 24 PARGANAS, KOLKATA - 700151

Sanyalson Associates
 Consultants Pvt. Ltd.
 23, 24, 25, 26, 27, 28, 29, 30, 31, 32, 33, 34, 35, 36, 37, 38, 39, 40, 41, 42, 43, 44, 45, 46, 47, 48, 49, 50, 51, 52, 53, 54, 55, 56, 57, 58, 59, 60, 61, 62, 63, 64, 65, 66, 67, 68, 69, 70, 71, 72, 73, 74, 75, 76, 77, 78, 79, 80, 81, 82, 83, 84, 85, 86, 87, 88, 89, 90, 91, 92, 93, 94, 95, 96, 97, 98, 99, 100

RAI ABRAHAM & ASSOCIATES
 10, 11, 12, 13, 14, 15, 16, 17, 18, 19, 20, 21, 22, 23, 24, 25, 26, 27, 28, 29, 30, 31, 32, 33, 34, 35, 36, 37, 38, 39, 40, 41, 42, 43, 44, 45, 46, 47, 48, 49, 50, 51, 52, 53, 54, 55, 56, 57, 58, 59, 60, 61, 62, 63, 64, 65, 66, 67, 68, 69, 70, 71, 72, 73, 74, 75, 76, 77, 78, 79, 80, 81, 82, 83, 84, 85, 86, 87, 88, 89, 90, 91, 92, 93, 94, 95, 96, 97, 98, 99, 100

